

Capitolul 6

Sudarea si taierea cu flacara



Sudarea si taierea cu flacara

Schema tip a unei instalatii de sudare si taiere cu flacara

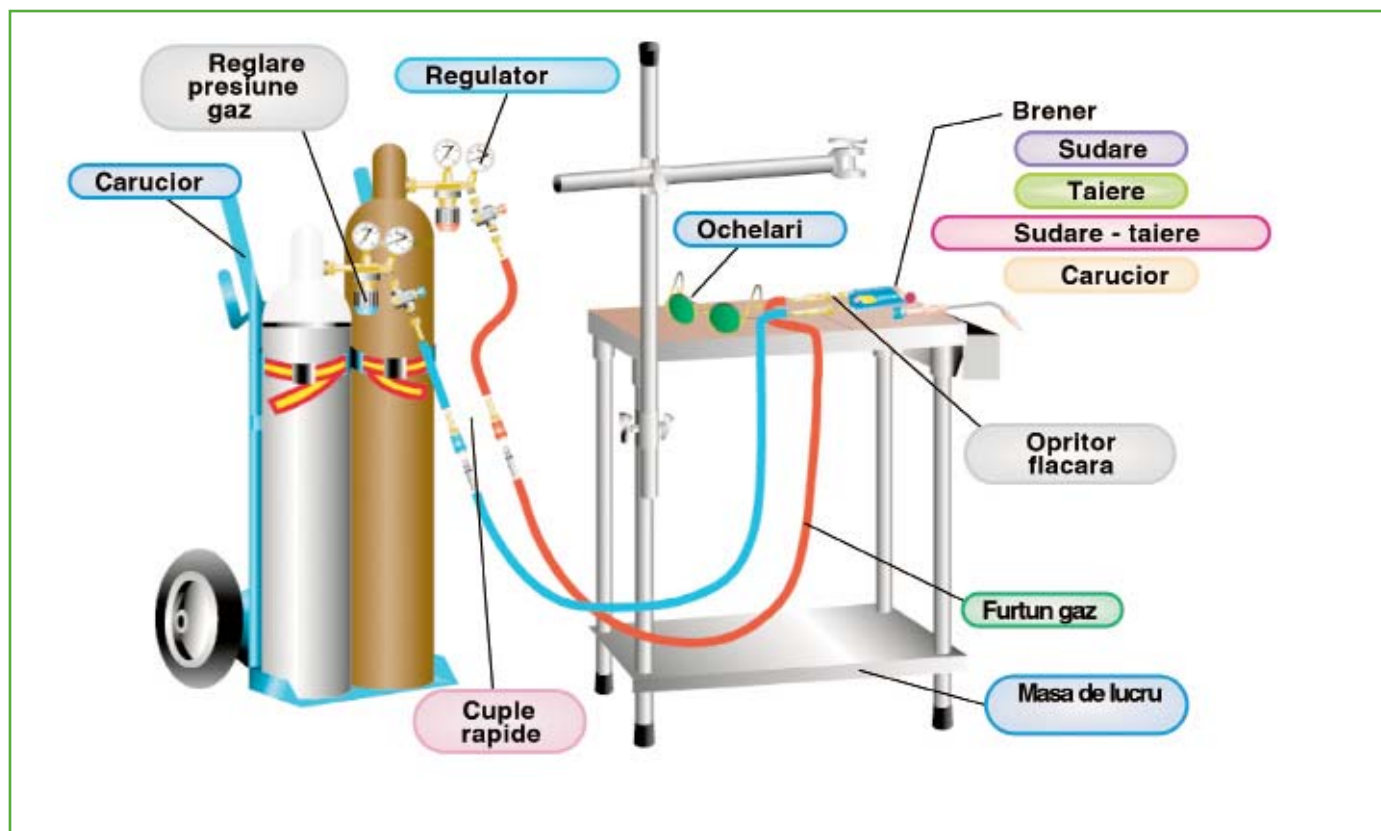

Generalitati

Date tehnice

BECURI SUDARE/INCALZIRE

Masura OX - AD	Presiune (bar)		Debit (l/h)		Masura OX - Prop./Met.	Presiune (bar)		Debit (l/h)	
	OX	AD	OX	AD		OX	Prop./Met.	OX	Prop./Met.
25	1,5	0,05	27,5	25	0P	2,5	0,2	44	12,5
40	1,5	0,05	48,4	40	1P	2,5	0,2	70	20
80	1,5	0,05	88	80	2P	2,5	0,2	140	40
160	2,5	0,05	176	160	3P	2,5	0,2	280	80
225	2,5	0,1	248	225	-	-	-	-	-
315	2,5	0,1	346	315	4P	2,5	0,1	540	155
500	2,5	0,1	550	500	5P	2,5	0,1	875	250
800	2,5	0,1	880	800	6P	2,5	0,1	1.400	400
1.250	2,5	0,1	1.375	1.250	7P	2,5	0,1	2.100	600
2.500	3	0,3	2.750	2.500	9P	4,0	0,25	6.000	1.600
4.000	3	0,4	4.400	4.000	11P	4,0	0,65	8.500	2.500

DUZE TAIERE IC

Grosime	Presiune (bar)		Debit (l/h)	
	OX	AD	OX	AD
25 mm	3,0	0,25	3.550	500
50 mm	3,0	0,28	5.800	700
100 mm	3,5	0,30	10.400	800
200 mm	5,0	0,45	21.400	1.250
300 mm	6,0	0,5	31.600	1.400

Presiune (bar)		Debit (l/h)	
OX	Propan	OX	Propan
3,0	0,12	4.600	400
3,0	0,15	6.800	450
3,5	0,18	11.500	500
5,0	0,18	22.400	600
6,0	0,2	33.200	800

Grosime	Presiune (bar)		Debit (l/h)	
	OX	Tetrene/Flamal	OX	Tetrene/Flamal
25 mm	3,0	0,25	4.700	1.000
50 mm	3,0	0,28	6.900	1.150
100 mm	3,5	0,30	11.600	1.250
200 mm	5,0	0,45	22.500	1.500
300 mm	6,0	0,5	33.400	2.000

DUZE TAIERE H1F

Grosime	Presiune (bar)		Debit (l/h)	
	OX	AD	OX	AD
25 mm	3,0	0,35	3.550	500
50 mm	3,0	0,4	5.720	650
75 mm	3,5	0,4	8.830	750
100 mm	3,5	0,45	11.400	800
150 mm	4,0	0,5	17.100	950

Presiune (bar)		Debit(l/h)	
OX	Propan	OX	Propan
3,0	0,2	4.600	300
3,0	0,3	6.800	400
3,5	0,3	9.900	470
3,5	0,4	12.600	530
4,0	0,4	18.400	600

Grosime	Presiune (bar)		Debit (l/h)	
	OX	Tetrene/Flamal	OX	Tetrene/Flamal
25 mm	3,0	0,35	4.300	750
50 mm	3,0	0,4	6.700	1.000
75 mm	3,5	0,4	10.000	1.200
100 mm	3,5	0,45	12.800	1.350
150 mm	4,0	0,5	18.600	1.500

OX - oxigen
AD - acetilena

Sudarea si taierea cu flacara

Reductoare de presiune pentru gaze industriale de tip EUROFRO, sistem de reglare cu piston, supapa de siguranta la supra-presiune cu evacuare indirecta, sigiliu pe fiecare produs care garanteaza originea si integritatea produsului, calota de protectie anti-soc. Sunt construite conform EN ISO 2503.



E U R O F R O

COD PRODUS	0600684	0610105	0625293	0623918
Gaz folosit	OXIGEN	ACETILENA	PROPAN	Ar/CO ₂
Presiune max. la intrare	200 bari	25 bari	--	200 bari
Presiune max. la iesire	10 bari	1,5 bari	4	--
Debit max. (m ³ /h)	35	10	10	20 l/min
Tip racord la intrare	DIN 447-Nr.9/R3/4	DIN 447-Nr.3	DIN447-Nr.1/W21,8x1/14LH	DIN447-Nr.1/W21,8x1/14
Tip racord la iesire	DIN 4582-R1/4	DIN 4582-R3/8LH	DIN 4582-R3/8LH	DIN 4582-R1/4

Piese de uzura pentru EUROFRO

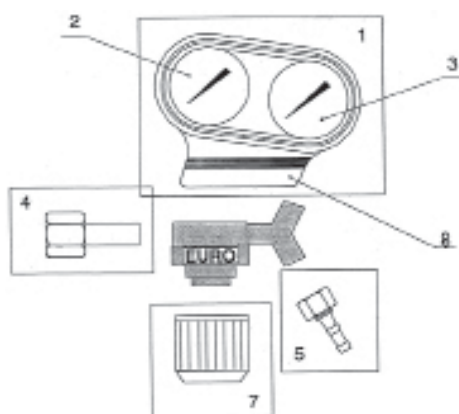

	cod
Kit 2 manometre + calota OX - Poz. 1	0697094
Kit 2 manometre + calota AD - Poz. 1	0697102
Set 5 manometre A.P. AD - Poz. 2	0630244
Set 5 manometre A.P. OX - Poz. 2	0630269
Set 5 manometre B.P. OX - Poz. 3	0630251
Set 5 manometre B.P. AD - Poz. 3	0630277
Set 5 racord intrare OX - Poz. 4	0691097
Set 5 racord intrare AD Filet. - Poz. 4	0691659
Set 5 racord intrare AD Scarita - Poz. 4	0691592
Set 5 piulite + racord furtun D.8-OX - Poz. 5	1104652
Set 5 piulite + racord furtun D.5-OX - Poz. 5	1103779
Set 5 piulite + racord furtun D.8-AD - Poz. 5	1104686
Set 5 piulite + racord furtun D.5-AD - Poz. 5	1103787
Set 5 OX - Poz. 7	0699538
Set 5 rozete AD - Poz. 7	0699546
Scarita AD	0633503
Set 5 calote albastre - Poz.8	0698605
Set 5 calote rosii - Poz.8	0698613

Reductoare de presiune pentru gaze industriale in butelii

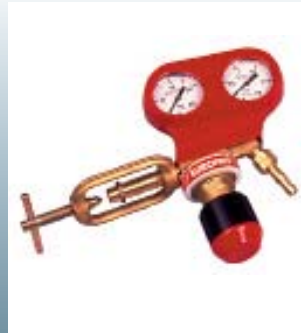

0624346
Ar/CO ₂
200 bari
--
25 l/min
DIN447-Nr.1/W21,8x1/14
DIN 4582-R1/4

Lista preturi

Denumire produs	Cod	Pret EuroDisp.CMC
Reductor EUROFRO -OXIGEN	0600684	A 1
Reductor EUROFRO -ACETILENA	0610105	A 1
Reductor EUROFRO -Ar/CO ₂ cu coloana	0623918	A 1
Reductor EUROFRO -Ar/CO ₂	0624346	A 1
Reductor EUROFRO -PROPAN	0625293	A 1
Kit 2 manometre + calota OX - Poz. 1	0697094	B 3
Kit 2 manometre + calota AD - Poz. 1	0697102	B 3
Set 5 manometre A.P. AD - Poz. 2	0630244	B 1
Set 5 manometre A.P. OX - Poz. 2	0630269	B 1
Set 5 manometre B.P. OX - Poz. 3	0630251	B 1
Set 5 manometre B.P. AD - Poz. 3	0630277	B 1
Set 5 racord intrare OX - Poz. 4	0691097	B 1
Set 5 racord intrare AD Filet. - Poz. 4	0691659	B 1
Set 5 racord intrare AD Scarita - Poz. 4	0691592	B 1
Set 5 piulite + racord furtun D.8-OX - Poz. 5	1104652	B 1
Set 5 piulite + racord furtun D.5-OX - Poz. 5	1103779	B 1
Set 5 piulite + racord furtun D.8-AD - Poz. 5	1104686	B 1
Set 5 piulite + racord furtun D.5-AD - Poz. 5	1103787	B 1
Set 5 OX - Poz. 7	0699538	B 1
Set 5 rozete AD - Poz. 7	0699546	B 1
Scarita AD	0633503	A 2
Set 5 calote albastre - Poz. 8	0698605	B 1
Set 5 calote rosii - Poz. 8	0698613	B 1



Sudarea si taierea cu flacara

FROVER: breneri cu lantii interschimbabile pentru sudare, brazare, incalzire si debitare. La sudare si brazare se pot folosi la grosimi intre 0,3 mm-20 mm si la taiere pentru grosimi intre 3 mm-200 mm. Usoare sunt ideale pentru ateliere mici, service-uri auto, constructii metalice usoare. Sunt construite in conformitate cu standardele ISO, UNI si DIN.

Brenere pentru sudare si brazare - Acetilena



FROVER

Gama FROVER este o gama special creata pentru a asigura executia oricarui tip de sudura, brazare, incalzire sau taiere. Acest sortiment include toate tipurile de lantii care se pot monta pe 2 tipuri de manere: usor din aluminiu sau monobloc din bronz.



COD PRODUS	W000290003	W000290004
Tip constructiv	monobloc-aluminiu	monobloc-alama
Tip racord la iesire	niplu G3/8" - Ø 6-8 mm	niplu G3/8" - Ø 6-8 mm
Utilizare	sudare/brazare/incalzire/taiere	sudare/brazare/incalzire/taiere
Domenii grosimi	sudare si brazare : 0,3-20mm / taiere : 3-200mm	

Lantii pentru sudare si sudo-brazare Acetilena



Debit	Grosimi	Cod lance sudare	Cod bec schimb
40 l/h -	Grosime 0,4 mm	W000290025	W000294019
80 l/h -	Grosime 0,8 mm	W000290026	W000294020
160 l/h -	Grosime 2 mm	W000290027	W000294021
225 l/h -	Grosime 3 mm	W000290028	W000294022
315 l/h -	Grosime 4 mm	W000290029	W000294023
500 l/h -	Grosime 5 mm	W000290030	W000294024
800 l/h -	Grosime 8 mm	W000290031	W000294025
1250 l/h -	Grosime 14 mm	W000290032	W000294026
1800 l/h -	Grosime 18 mm	--	W000294027

Brenere pentru sudare si brazare - gama FROVER



Lanci curbabile-acetilena



Debit	Grosimi	Cod lance sudare	Cod tub schimb
225 l/h	Grosime 3 mm	W000290033	0544031
315 l/h	Grosime 4 mm	W000290034	0544049
500 l/h	Grosime 5 mm	W000290035	0544056

Lista preturi

Denumire produs	Cod	Pret EuroDisp.CMC
Maner FROVER usor - aluminiu	W000290003	A 1
Maner FROVER - alama	W000290004	A 1
Lance sudare 40 l/h - Grosime 0,4 mm	W000290025	B 1
Lance sudare 80 l/h - Grosime 0,8 mm	W000290026	B 1
Lance sudare 160 l/h - Grosime 2 mm	W000290027	B 1
Lance sudare 225 l/h - Grosime 3 mm	W000290028	B 1
Lance sudare 315 l/h - Grosime 4 mm	W000290029	B 1
Lance sudare 500 l/h - Grosime 5 mm	W000290030	B 1
Lance sudare 800 l/h - Grosime 8 mm	W000290031	B 1
Lance sudare 1250 l/h -Grosime 14 mm	W000290032	B 1
Bec 40 l/h - Grosime 0,4 mm	W000294019	B 1
Bec 80 l/h - Grosime 0,8 mm	W000294020	B 1
Bec 160 l/h - Grosime 2 mm	W000294021	B 1
Bec 225 l/h - Grosime 3 mm	W000294022	B 1
Bec 315 l/h - Grosime 4 mm	W000294023	B 1
Bec 500 l/h - Grosime 5 mm	W000294024	B 1
Bec 800 l/h - Grosime 8 mm	W000294025	B 1
Bec 1250 l/h -Grosime 14 mm	W000294026	B 1
Bec 1800 l/h -Grosime 18 mm	W000294027	B 1
Lance curb. 225 l/h - Grosime 3 mm	W000290033	B 1
Lance curb. 315 l/h - Grosime 4 mm	W000290034	B 1
Lance curb. 500 l/h - Grosime 5 mm	W000290035	B 1



Sudarea si taierea cu flacara

FROVER: breneri cu lantii interschimbabile pentru sudare, brazare, incalzire si debitare. La sudare si brazare se pot folosi la grosimi intre 0,3 mm-20 mm si la taiere pentru grosimi intre 3 mm-200 mm. Usoare sunt ideale pentru ateliere mici, service-uri auto, constructii metalice usoare. Sunt construite in conformitate cu standardele ISO, UNI si DIN.

Brenere pentru taiere cu flacara



FROVER

Gama FROVER este o gama special creata pentru a asigura executia oricarui tip de sudura, brazare, incalzire sau taiere. Acest sortiment include toate tipurile de lantii care se pot monta pe 2 tipuri de manere: usor din aluminiu sau monobloc din bronz.



COD PRODUS	W000290003	W000290004
Tip constructiv	monobloc-aluminiu	monobloc-alama
Tip racord la iesire	niplu G3/8" - Ø 6-8 mm	niplu G3/8" - Ø 6-8 mm
Utilizare	sudare/brazare/incalzire/taiere	sudare/brazare/incalzire/taiere
Domenii grosimi	sudare si brazare : 0,3-20mm / taiere : 3-200mm	

Lantii pentru taiere FROVER H1F



COD PRODUS	Gaz comb.	Tip	Grosime max.
0508100	Acetilena	cu absortie	150 mm
0508110	Propan-Metan	cu absortie	150 mm
0508499	Acetilena-Propan-Metan	cu egalizare	150 mm

Brenere pentru taiere cu flacara - gama FROVER



Becuri pentru taiere H1F



Grosimi	Acetilena	Propan - Metan
10	W000294050	W000294062
25	W000294051	W000294063
50	W000294052	W000294064
75	W000294053	W000294065
100	W000294054	W000294066
150	W000294055	W000294067

Lanci pentru taiere FROVER IC



COD PRODUS	Gaz comb.	Tip	Grosime max.
W000290046	Acetilena-Propan-Metan	cu egalizare/ cu robinet	200 mm
W000290047	Acetilena-Propan-Metan	cu egalizare/ cu parghie	200 mm

Becuri pentru taiere IC



Grosimi	Acetilena	Propan	Metan
10	0545244	0545335	0545426
25	0545251	0545343	0545434
50	0545269	0545350	0545442
100	0545277	0545368	0545459
200	0545285	0545376	0545467

Accesorii



Produs	H1F cu robinet	H1F cu parghie	IC
Compas	0520379	0520460	W000290054
Carucior cu role	0528323	W000290052	W000290052

Sudarea si taierea cu flacara

FROVER: breneri cu lantii interschimbabile pentru sudare, brazare, incalzire si debitare. La sudare si brazare se pot folosi la grosimi intre 0,3 mm-20 mm si la taiere pentru grosimi intre 3 mm-200 mm. Usoare sunt ideale pentru ateliere mici, service-uri auto, constructii metalice usoare. Sunt construite in conformitate cu standardele ISO, UNI si DIN.

Brenere pentru incalzire cu flacara



Amestecator



COD PRODUS	Gaz comb.
0590604	Propan-Metan

Extensie inox intre amestecator si duza



Denumire	COD PRODUS	Lungime mm
	0544478	700
Extensie curba	0544460	700
	0544452	350

Incalzitor pe gaz Propan-Metan



Tip	COD	Oxigen m ³ /h	Propan m ³ /h	Kcal/h	Btu/h
5000 - 12PM	0549618	6 - 11	1,5 - 2,7	61000	242000
6500 - 13PM	0549626	8 - 18	2 - 4,5	100000	396000
8000 - 14PM	0549634	12 - 25	3 - 6,2	138000	550000
10000 - 15PM	0549642	15 - 36	3,8 - 9	200000	790000

Lantii pentru incalzire - multiple



Acetilena			Propan - Metan		
Tip	COD	Kcal/h	Tip	COD	Kcal/h
1250 l/h	0504076	17000	1250 - 7PM	0504466	15000
2500 l/h	0504100	34000	2500 - 9PM	0505453	30000
4000 l/h	0504134	54500	4000 - 11PM	0505461	35000

Brenere pentru incalzire cu flacara - gama FROVER



Lista preturi

Denumire produs	Cod	Pret Euro	Disp.CMC
Maner FROVER usor-aluminiu	W000290003	A	1
Maner FROVER - alama	W000290004	A	1
Lance de taiere H1F-A- cu robinet	0508100	A	1
Lance de taiere H1F PM - cu robinet	0508110	A	1
Lance de taiere H1F - cu parghie	0508499	A	1
Lance de taiere IC - cu robinet	W000290046	A	1
Lance de taiere IC - cu parghie	W000290047	A	1
Duza H1F -10 mm- acetilena	W000294050	A	3
Duza H1F-25 mm- acetilena	W000294051	A	3
Duza H1F-50 mm- acetilena	W000294052	A	3
Duza H1F-75 mm- acetilena	W000294053	A	3
Duza H1F-100 mm- acetilena	W000294054	A	3
Duza H1F-150 mm- acetilena	W000294055	A	3
Duza H1F-10 mm- PM	W000294062	A	3
Duza H1F-25 mm- PM	W000294063	A	3
Duza H1F-50 mm- PM	W000294064	A	3
Duza H1F-75 mm- PM	W000294065	A	3
Duza H1F-100 mm- PM	W000294066	A	3
Duza H1F-150 mm- PM	W000294067	A	3
Duza IC -10 mm- acetilena	0545244	A	3
Duza IC -25 mm- acetilena	0545251	A	3
Duza IC -50 mm- acetilena	0545269	A	3
Duza IC -100 mm- acetilena	0545277	A	3
Duza IC -200 mm- acetilena	0545285	A	3
Duza IC -10 mm- propan	0545335	A	3
Duza IC -25 mm- propan	0545343	A	3
Duza IC -50 mm- propan	0545350	A	3
Duza IC -100 mm- propan	0545368	A	3
Duza IC -200 mm- propan	0545376	A	3
Duza IC -10 mm- metan	0545426	C	3
Duza IC -25 mm- metan	0545434	B	3
Duza IC -50 mm- metan	0545442	A	3
Duza IC -100 mm- metan	0545459	A	3
Duza IC -200 mm- metan	0545467	A	3
Compas H1F cu robinet	0520379	A	1
Compas H1F cu parghie	0520460	A	1
Carucior cu rotile H1F cu robinet	0528323	A	1
Carucior cu rotile H1F cu parghie	0520262	A	1
Carucior cu rotile IC	0520262	A	1
Compas IC	0520361	A	1

Denumire produs	Cod	Pret Euro	Disp.CMC
Amestecator din alama	0590604	B	1
Extensie dreapta L = 700 mm din otel	0544478	B	1
Extensie curba L = 700 mm din otel	0544460	B	1
Extensie curba L = 350 mm din otel	0544452	B	1
Bec incalzitor 5000 - 12 PM	0549618	B	1
Bec incalzitor 6500 - 13 PM	0549626	B	1
Bec incalzitor 8000 - 14 PM	0549634	B	1
Bec incalzitor 10000 - 15 PM	0549642	B	1
Lance acetilena 1250 l/h	0504076	B	1
Lance acetilena 2500 l/h	0504100	B	1
Lance acetilena 4000 l/h	0504134	B	1
Bec acetilena 1250 l/h	0542571	B	1
Bec acetilena 2500 l/h	0542969	B	1
Bec acetilena 4000 l/h	0542704	B	1
Lance 1250 - 7 PM	0504266	B	1
Lance 2500 - 9 PM	0505453	B	1
Lance 4000 - 11 PM	0505461	B	1
Bec Propan/Metan - 7 PM	0542647	B	1
Bec Propan/Metan - 9 PM	0543306	B	1
Bec Propan/Metan - 11 PM	0543314	B	1



Brenere pentru taiere oxi-gaz

BETA H1F si SIRIOJET IC: brenere compacte pentru taiere cu flacara oxi-gaz pentru grosimi cuprinse intre 3 mm si 300 mm.

BETA H1F brener compact recomandat pentru grosimi intre 3 mm-150 mm, este usor (1 kg) si se fabrica in doua variante: cu robinet si cu parghie pentru comanda jetului de oxigen la taiere.

SIRIOJET IC brener compact recomandat pentru grosimi intre 3 mm-200 mm se fabrica in patru variante functie de sistemul de comanda al jetului de oxigen(cu parghie sau robinet) sau de inclinarea a capului (90° sau 105°) si la diferite lungimi(500 mm-1000 mm)

Brenere compacte pentru taiere oxi-gaz



Tip brener	Cod	Tip duza	Gros.max.	Lungime	Greutate	Unghi inclinare
BETA H1F-cu robinet	0506196	H1F	150 mm	450 mm	1 kg	90 ⁰
BETA H1F- cu parghie	0506204	H1F	150 mm	450 mm	1 kg	90 ⁰
SIRIOJET-IC- cu robinet	0506220	IC	300 mm	500 mm	1,1 kg	90 ⁰
SIRIOJET-IC- cu parghie	0506238	IC	300 mm	500 mm	1,1 kg	90 ⁰
SIRIOJET-IC- cu parghie	0506311	IC	300 mm	800 mm	1,3 kg	105 ⁰
SIRIOJET-IC- cu parghie	0506218	IC	300 mm	1000 mm	1,4 kg	105 ⁰

Duze pentru taiere H1F



Grosimi	Acetilena	Propan - Metan
10	W000294050	W000294062
25	W000294051	W000294063
50	W000294052	W000294064
75	W000294053	W000294065
100	W000294054	W000294066
150	W000294055	W000294067

Duze pentru taiere IC



Grosimi	Acetilena	Propan	Metan
10	0545244	0545335	0545426
25	0545251	0545343	0545434
50	0545269	0545350	0545442
100	0545277	0545368	0545459
200	0545285	0545376	0545467
300	0545293	0545384	0545475

Brenere pentru taiere cu flacara - gama BETA H - SIRIOJET IC



Accesorii



Produs	BETA H1F	SIRIOJET IC
Compas	0520460	0520361
Carucior cu role	0520262	0520262

Lista preturi

Denumire produs	Cod	Pret Euro	Disp.CMC
Brener BETA H1F-cu robinet - 90°	0506196	A	1
Brener BETA H1F- cu parghie- 90°	0506204	A	1
Brener SIRIOJET-IC- cu robinet- 90°	0506220	A	1
Brener SIRIOJET-IC- cu parghie- 90°	0506238	A	1
Brener SIRIOJET-IC- cu parghie- 105°	0506311	B	1
Brener SIRIOJET-IC- cu parghie- 105°	0506218	B	1
Duza H1F -10 mm- acetilena	W000294050	A	3
Duza H1F-25 mm- acetilena	W000294051	A	3
Duza H1F-50 mm- acetilena	W000294052	A	3
Duza H1F-75 mm- acetilena	W000294053	A	3
Duza H1F-100 mm- acetilena	W000294054	A	3
Duza H1F-150 mm- acetilena	W000294055	A	3
Duza H1F-10 mm- PM	W000294062	A	3
Duza H1F-25 mm- PM	W000294063	A	3
Duza H1F-50 mm- PM	W000294064	A	3
Duza H1F-75 mm- PM	W000294065	A	3
Duza H1F-100 mm- PM	W000294066	A	3
Duza H1F-150 mm- PM	W000294067	A	3
Duza IC -10 mm- acetilena	0545244	A	3

Denumire produs	Cod	Pret Euro	Disp.CMC
Duza IC -25 mm- acetilena	0545251	A	3
Duza IC -50 mm- acetilena	0545269	A	3
Duza IC -100 mm- acetilena	0545277	A	3
Duza IC -200 mm- acetilena	0545285	A	3
Duza IC -10 mm- propan	0545335	A	3
Duza IC -25 mm- propan	0545343	A	3
Duza IC -50 mm- propan	0545350	A	3
Duza IC -100 mm- propan	0545368	A	3
Duza IC -200 mm- propan	0545376	A	3
Duza IC -10 mm- metan	0545426	C	3
Duza IC -25 mm- metan	0545434	B	3
Duza IC -50 mm- metan	0545442	A	3
Duza IC -100 mm- metan	0545459	A	3
Duza IC -200 mm- metan	0545467	A	3
Compas BETA H1F	0520460	A	1
Carucior cu rotile H1F - SIRIOJET IC	0520262	A	1
Carucior cu rotile IC	0520262	A	1
Compas IC	0520361	A	1



Trusa pentru sudare si taiere

FROVERKIT 1: trusa in cutie metalica, compacta si practica pentru sudare si taiere cu flacara oxi-acetilenica. Echipamentul de sudare si taiere este conform gamei FROVER.



Trusa FROVERKIT 1 Dimensiuni

	Cod	Lungime	Inaltime	Latime	Greutate
Trusa FROVERKIT 1	0526186	390 mm	255 mm	80 mm	4,5 kg

Componenta

Denumire	Cod	Nr. buc.
Maner FROVER alama	0500561	1
Lance taiere H1F ISO 5172 cu robinet	0508100	1
Duza taiere H1F - 25mm-acetilena	0545111	1
Duza taiere H1F - 50mm-acetilena	0545129	1
Dispozitiv de siguranta SECURTOP-TF-OX	1102654	1
Dispozitiv de siguranta SECURTOP-TF-GC	1102655	1
Lance sudare 80 l/h - 0,8mm-acetilena	W000290026	1
Lance sudare 160 l/h - 2mm-acetilena	W000290027	1
Lance sudare 315 l/h - 4mm-acetilena	W000290029	1
Lance sudare 500 l/h - 5mm-acetilena	W000290030	1
Lance sudare flexibila 315 l/h-acetilena	0501593	1

FROVERKIT 1



Lista preturi

Denumire produs	Cod	Pret Euro	Disp.CMC
Trusa FROVERKIT 1	0526186		A 1
Maner FROVER alama	0500561		A 1
Lance taiere H1F ISO 5172 cu robinet	0508100		A 1
Duza taiere H1F - 25mm-acetilena	W000294051		A 1
Duza taiere H1F - 50mm-acetilena	W000294052		A 1
Dispozitiv de siguranta SECUR TOP-TF-OX	1102654		A 1
Dispozitiv de siguranta SECUR TOP-TF-GC	1102655		A 1
Lance sudare 80 l/h - 0,8mm-acetilena	W000290026		A 1
Lance sudare 160 l/h - 2mm-acetilena	W000290027		A 1
Lance sudare 315 l/h - 4mm-acetilena	W000290029		A 1
Lance sudare 500 l/h - 5mm-acetilena	W000290030		A 1
Lance sudare flexibila 315 l/h-acetilena	0501593		A 1

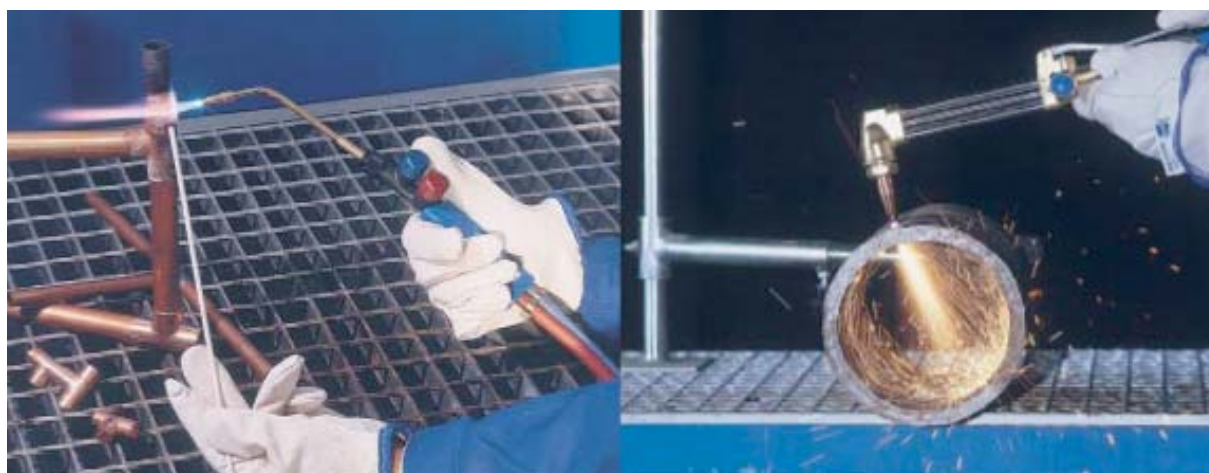

Masini portabile pentru taiere

PRATIC: masina portabila pentru debitat cu flacara oxi-gaz pe lungimi mari. Usor de manevrat, greutate mica (10kg) are o viteza de deplasare de la 10 mm/min la 1000 mm/min, cu reglarea continua a vitezei. Are posibilitatea inversarii sensului de miscare cu ajutorul unui comutator. Poate taia grosimi pana la 150 mm.

PYROTOME-SE: masina portabila pentru debitat cu flacara oxi-gaz. Este robusta cu posibilitate de ghidare pe o cale speciala sau pe un cornier. Usor de manevrat poate taia grosimi pana la 300 mm.

	PRATIC	PYROTOME-SE
	Masina portabila pentru debitat cu flacara oxi-gaz. Poate folosi gaz combustibil atat acetilena cat si propan-metan.	Masina portabila pentru debitat cu flacara cu viteza de taiere pana la 1250 mm/min. Poate taia pana la grosimi de 300 mm.
COD PRODUS	W000209421	W000138864
Tensiune de alimentare	230 V - 1 Ph	230 V - 1 Ph
Frecventa curentului la retea	50 / 60 Hz	50 / 60 Hz
Viteza	pana la 100 cm/min	pana la 125 cm/min
Grosimi de taiere	5 mm-150 mm	5 mm-300 mm
Diametre de taiere (Ø mm)	85 mm-630 mm (standard)	130 mm-1 500 mm (standard)
Posibilitate inclinare cap taiere	± 45 ⁰	± 45 ⁰
Greutate	10 kg	28 kg
Dimensiuni (mm)	210x380x450	240x190x510
Dotare standard	-1 carucior, 1 suport brener, 1 cremaliera, 1 contra-greutate pentru compas, 1 ecran termic, 1 cablu de alimentare la 220V cu stecher, 1 transformator 220V/42V cu cablu(fara brener)	-1 carucior, 1 suport brener, 1 cremaliera, 1 ecran termic, 1 cablu de alimentare la 220V cu stecher, 1 transformator 220V/42V cu cablu
Brener acetilena	- 0507335 - Brener H1F*	--
Brener - propan-metan	- 0507343 - Brener H1F*	--
Brener - acetilena-propan-metan	- 0507426 - Brener IC**	- 7617-1521 - Brener OXYSAF G1
Brat cremaliera suplimentar L=350mm	- 0700211	--
Cupla	- 0700161	--
Kit instalare brener suplimentar	- 0700187 (H1F)	- 0696-1250
Compas cu contra-greutate	--	- 0696-1190
Kit racorduri in Y	--	- W000241918
Ghidaje laterale pentru L=40x40	--	- 0696-1175 (trebuie sc 2 bucati)
Cale rulare 2 m	--	- 37800500
Suport rotativ pentru cremaliera	--	- 0696-1130
Protectie laterala	--	- 0696-1110

*) ** duze vezi pag.88

Duze taiere pentru brener G1

Grosimi	Acetilena	Propan	Metan
3-10	W000262059	W000262066	7018-1635
10-25	W000262060	W000262067	7018-1636
25-50	W000262061	W000262068	7018-1637
50-80	W000262062	W000262069	7018-1638
80-120	W000262063	W000262070	7018-1639
120-200	W000262064	W000262071	7018-1640
200-300	W000262065	W000262072	7018-1641

PRATIC - PYROTOME-SE



Lista preturi

Denumire produs	Cod	Pret Euro	Disp.CMC
PRATIC	W000209421	B	1
Brener H1F -acetilena	0507335	B	1
Brener H1F -propan-metan	0507343	B	1
Brener IC-acetilena-propan-metan	0507426	B	1
Bara cremaliera suplimentara L=350mm	0700211	B	1
Cupla bara	0700161	B	1
Kit instalare brener suplimentar	0700187	B	1
PYROTOME-SE	W000138864	B	1
Brener OXYSAF G1	7617-1521	B	1
Ansamblu brener suplimentar	0696-1250	B	1
Kit racorduri in Y	W000241918	B	1
Cale rulare 2 m	37800500	B	1
Ghidaje laterale pentru L=40x40	0696-1175	B	1
Suport rotativ pentru cremaliera	0696-1130	B	1
Protectie laterala	0696-1110	B	1
Compas cu contragreutate	0696-1190	B	1
Duza acetilena 3-10mm	W000262059	B	1
Duza acetilena 10-25mm	W000262060	B	1
Duza acetilena 25-50mm	W000262061	B	1
Duza acetilena 50-80mm	W000262062	B	1
Duza acetilena 80-120mm	W000262063	B	1
Duza acetilena 120-200mm	W000262064	B	1
Duza acetilena 200-300mm	W000262065	B	1
Duza propan 3-10mm	W000262066	B	1
Duza propan 10-25mm	W000262067	B	1
Duza propan 25-50mm	W000262068	B	1
Duza propan 50-80mm	W000262069	B	1
Duza propan 80-120mm	W000262070	B	1
Duza propan 120-200mm	W000262071	B	1
Duza propan 200-300mm	W000262072	B	1
Duza metan 3-10mm	7018-1635	B	1
Duza metan 10-25mm	7018-1636	B	1
Duza metan 25-50mm	7018-1637	B	1
Duza metan 50-80mm	7018-1638	B	1
Duza metan 80-120mm	7018-1639	B	1
Duza metan 120-200mm	7018-1640	B	1
Duza metan 200-300mm	7018-1641	B	1

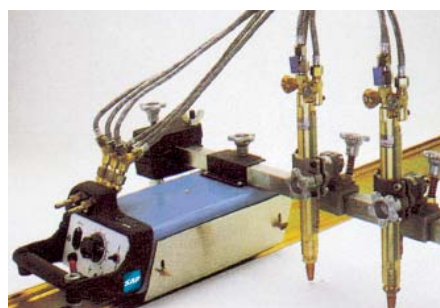

Dispozitive de siguranta

Gama SECUR: dispozitive de siguranta care opresc intoarcerea flacarii sau a gazului. Se schimba la maxim 5 ani, la o functionare corecta, sau ori de cate ori se intoarce flacara. Dispozitivele de siguranta care se folosesc la aparatele de sudarea si taierea oxigaz au rolul de a preveni accidentele atunci cand se fac manevre defectuoase sau se folosesc aparate defecte (brenere-reductoare-accesorii-furtunuri de gaz). Se recomanda folosirea a doua sisteme de siguranta: pe reductor si pe maner sau pe furtun. Sigure, compacte, usoare, acestea sunt fabricate conform ISO 5175 si ISO 3253.

SECURTOP 665 - montare pe reductor



Tip gaz	COD	Debit m ³ /h	Tip filet	Funcții
Oxigen	W000183861	25	G 3/8" DX	- Opreste intoarcerea flacarii
Gaz combustibil	W000183901	3	G3/8" SX	- Opreste intoarcerea gazului

SECURTOP 662-FF - montare pe maner



A



B

Tip gaz	COD	Debit m ³ /h	Tip prindere A	Tip prindere B	Funcții
Oxigen	1102658	35	G3/8" DX	G3/8" DX	- Opreste intoarcerea flacarii
Gaz combustibil	1102659	8	G3/8" SX	G3/8" SX	- Opreste intoarcerea gazului
Oxigen	1102660	35	G1/4" DX	G1/4" DX	
Gaz combustibil	1102661	8	G1/4" SX	G1/4" SX	

SECURTOP 662-TF - montare pe maner



A



B

Tip gaz	COD	Debit m ³ /h	Tip prindere A	Tip prindere B	Funcții
Oxigen	1102654	35	G3/8" DX	8 mm	- Opreste intoarcerea flacarii
Gaz combustibil	1102655	8	G3/8" SX	8 mm	- Opreste intoarcerea gazului
Oxigen	1102656	35	G1/4" DX	6,3 mm	
Gaz combustibil	1102657	8	G1/4" SX	6,3 mm	

SECURTOP 662-TT - montare pe furtun



A



B

Tip gaz	COD	Debit m ³ /h	Tip prindere A	Tip prindere B	Funcții
Oxigen	1102652	35	8-6 mm	8-6 mm	- Opreste intoarcerea flacarii
Gaz combustibil	1102653	8	8-6 mm	8-6 mm	- Opreste intoarcerea gazului
Oxigen	1102674	35	5 mm	5 mm	
Gaz combustibil	1102675	8	5 mm	5 mm	

SECURTOP; THERMOSTOP



THERMOSTOP 1 - montare pe reductor



Tip gaz	COD	Debit m ³ /h	Tip filet	Functii
Oxigen	1102995	25	G 3/8" DX	- Opreste intoarcerea flacarii
Gaz combustibil	1103001	3	G3/8" SX	- Opreste intoarcerea gazului

Lista preturi

Denumire produs	Cod	Pret Euro	Disp.CMC
SECURTOP- OXIGEN	W000183861	A	5
SECURTOP - GAZ COMBUSTIBIL	W000183901	A	5
SECURTOP 662 FF - OXIGEN 3/8"	1102658	A	5
SECURTOP 662 FF - GAZ COMB. 3/8"	1102659	A	5
SECURTOP 662 FF - OXIGEN 1/4"	1102660	A	5
SECURTOP 662 FF - GAZ COMB. 1/4"	1102661	A	5
SECURTOP 662 TF - OXIGEN 3/8"	1102654	A	5
SECURTOP 662 TF - GAZ COMB. 3/8"	1102655	A	5
SECURTOP 662 TF - OXIGEN 1/4"	1102656	A	5
SECURTOP 662 TF - GAZ COMB. 1/4"	1102657	A	5
SECURTOP 662 TT - OXIGEN 8-6	1102652	A	5
SECURTOP 662 TT - GAZ COMB 8-6	1102653	A	5
THERMOSTOP 1 - OXIGEN 3/8"	1102995	A	3
THERMOSTOP 1 - GAZ COMB 3/8"	1103001	A	3

